

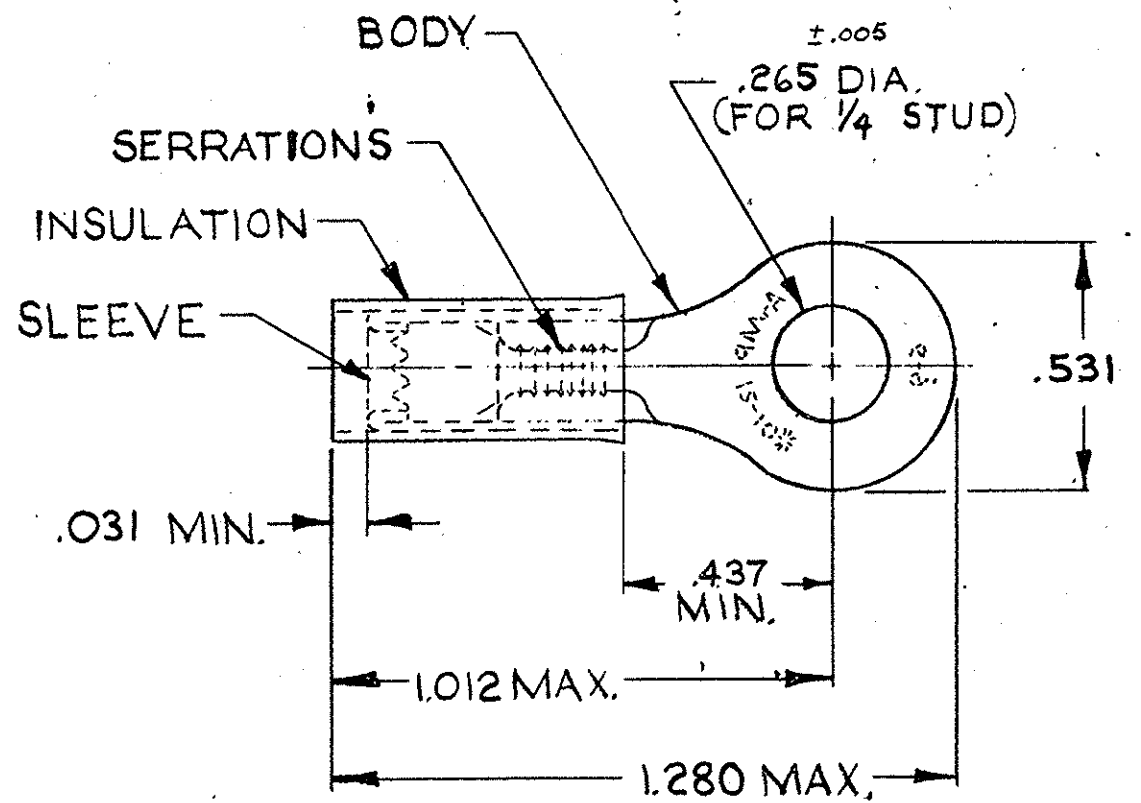

© 1967 BY AMP INCORPORATED. ALL RIGHTS RESERVED. AMP PRODUCTS COVERED BY PATENTS AND/OR PATENTS PENDING.

REVISIONS				
ZONE	LTR	DESCRIPTION	DATE	APPROVED
	B	REDRAWN & REV.	P-6077 <sup>SK</sup> 7-30-69	FCY
	C	REVISED	PC-5579 <sup>WM</sup> 10-8-70	me
	D	REVISED	PC-5578 <sup>TC</sup> 2-23-77	L.D.
	E	REV/0610-0094-98	2-4-99	ME/SH
	E1	REV PER ECR 05-013140	10/20/05	KE/TM



FOR .102 TO .214 WIRE INSULATION DIA.  
TONGUE MATERIAL THK. = .040 ±.002

QTY		DESCRIPTION	PART NO.	MATERIAL & FINISH	
		WIRE TERMINAL	50846	BODY: COPPER (ASTM B152) NICKEL PLATE (QQ-N-290) .0003 AVG EXT. THK. SLEEVE: COPPER (ASTM B152) NICKEL PL (QQ-N-290).00003 AVG. EXT. THK. INSULATION: TEFLON (ASTM D3295) COLOR: BLACK	
UNLESS OTHERWISE SPECIFIED DIMENSIONS ARE IN INCHES		CONTRACT NO. 11		 AMP INCORPORATED HARRISBURG, PENNSYLVANIA	
TOLERANCES ON: DECIMALS ±.008 ANGLES ± 5°		DR. <i>Steve Kautz</i> 7-29-69	NAME		
MATERIAL SEE TABLE		CHK. <i>F.L. [Signature]</i> 7-30-69	WIRE TERMINAL		
		APPD. <i>[Signature]</i> 8-6-69	PIDG™- STRATO-THERM-RING TONGUE		
		REL. <i>[Signature]</i> 8-6-69	WIRE SIZE: 12-10		
		DSGN APPD.	SIZE	CODE IDENT NO.	NUMBER
		OTHER APPD.	B	00779	50846
			SCALE	NTS	SHEET 10F1